

# TPC-1071H

## 10.4" SVGA TFT LED LCD Intel® Atom™ Dual-Core D525 Touch Panel Computer



### Features

- Intel® Atom™ D525 1.8 GHz processor
- 10.4" SVGA TFT LED LCD
- Compact design with die-cast Al alloy front bezel
- Fanless cooling system
- IP65 approved front panel
- PCIe and Mini PCIe expansion support
- Supports 4 GB DDR3 SDRAM
- Integrated 16-channel Digital I/O with isolation
- 1 MB Battery-backed SRAM
- Serial port isolation protection
- Supports Microsoft® WES7/XP/WES/WinCE
- Supports external antenna for wireless communication
- Supports field-bus communication for PLC connectivity



### Introduction

The TPC-1071H features a fanless low power consuming Intel® Atom™ Dual Core 1.8GHz processor 4GB DDR3 SDRAM and Resistive touch screen, and multiple I/O ports 2 x RS-232 with isolation, 1 x RS-422/485 with isolation. For data storage the fanless TPC devices also include: 1 x Compact Flash Slot and 1 x 2.5" SATA HDD. To expand function, this model provides PCIe and mini-PCIe expansion slots, an integrated 16-channel Digital I/O with isolation and 1MB Battery-backed SRAM.

### Specifications

#### General

- BIOS** AMI 8Mbit
- Certification** BSMI, CCC, CE, FCC Class A, UL
- Cooling System** Fanless design
- Dimensions (W x H x D)** 287.0 x 227.0 x 73.3 mm (11.30" x 8.94 x 2.89)
- Enclosure** Front bezel: Die-cast Aluminum alloy  
Back housing: PC/ABS Resin
- Mounting** Desktop, Wall or Panel Mount
- OS Support** Microsoft® Windows 7/WES7/WES 2009/XPE/CE 6.0/  
Linux / Android
- Power Consumption** 17W
- Power Input** 10~29 V<sub>DC</sub>
- Watchdog Timer** 1 ~ 255 sec (system)
- Weight (Net)** TPC-1071H: 3.5 kg (7.72 lbs)

#### System Hardware

- CPU** Intel® Atom™ D525 1.8 GHz with 1MB cache
- Chipset** ICH8M
- Memory** 4GB SO-DIMM DDR3 SDRAM
- LAN** 10/100/1000Base-T x 2
- Expansion Slots** Half-size PCI-E or full-size Mini PCI-E
- Storage** CompactFlash® slot x 1  
2.5" SATA HDD x 1 (Optional)
- I/O** RS-232 x 2 (COM1, 2) with isolation  
RS-422/485 x 1 (COM3) with isolation and auto data flow control  
USB 2.0 x 2 (Host)  
PS/2 x 1
- DI/DO & backup SRAM** 8 x DI/DO with isolation and backup 1MB SRAM

#### LCD Display

- Display Type** SVGA TFT LED LCD
- Display Size** 10.4"
- Max. Resolution** 800 x 600
- Max. Colors** 262 K
- Luminance cd/m<sup>2</sup>** 400
- Viewing Angle (H/V°)** 120/100
- Backlight Life** 50,000 hrs
- Contrast Ratio** 400:1

#### Touchscreen

- Lifespan** 10 million touches at single point
- Light Transmission** Above 75%
- Resolution** Linearity
- Type** 5-wire, analog resistive

#### Environment

- Humidity** 10 ~ 95% RH @ 40°C, non-condensing
- Ingress Protection** Front panel: IP65
- Operating Temperature** 0 ~ 55°C (32 ~ 131°F)
- Storage Temperature** -20 ~ 60°C (-4 ~ 140°F)
- Vibration Protection** With HDD: 1 Grms (5 ~ 500 Hz)  
(Operating, random vibration)

#### Rear View

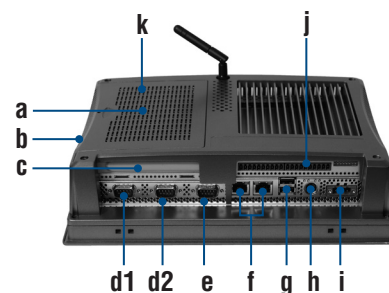

- a. HDD
- b. CompactFlash
- c. PCI-E slot
- d1. COM3 (RS-422/485)
- d2. COM2 (RS-232)
- e. COM1 (RS-232)
- f. LAN (10/100/1000)
- g. USB 2.0
- h. PS/2
- i. Power Receptor
- j. DI/O ports
- k. Mini PCI-E slot

## Dimensions

Unit: mm

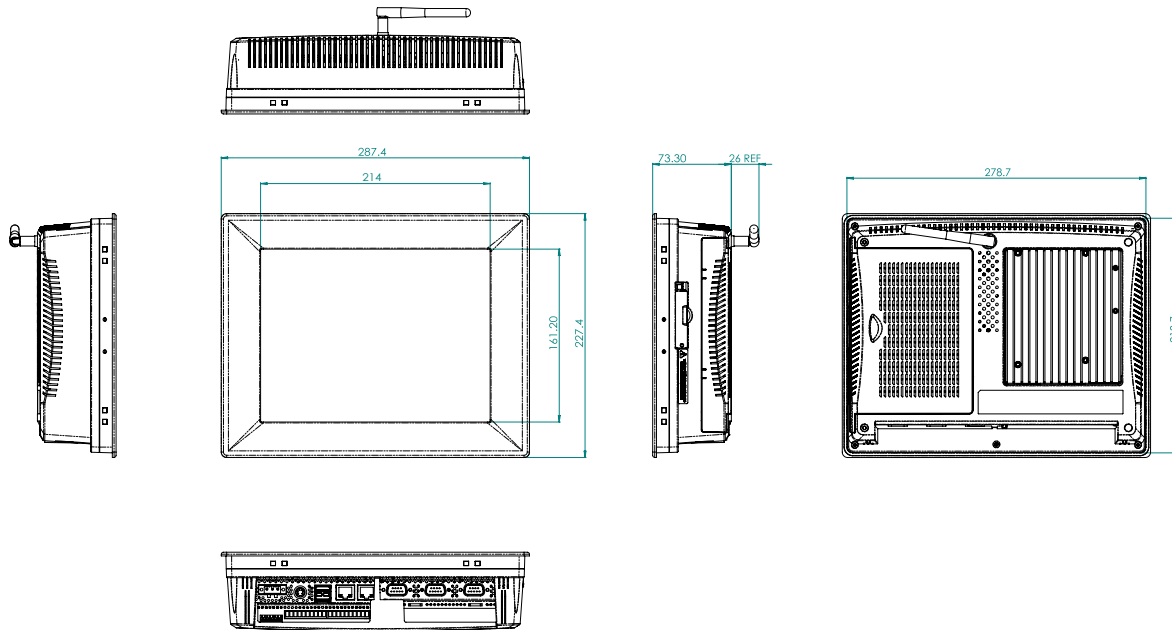

Panel Cut-out Dimensions: 279.5 x 219.5mm (11.00" x 8.64")

## Ordering Information

- TPC-1071H-D3AE 10.4" SVGA Touch Panel PC, D525 1.8 GHz, 4GB
- WA-TPC1071 TPC-1071H-D3AE with WebAccess software

## Accessories

- PWR-247-BE 63W DC 24V/2.62A Output Power Supply
- 1702002600 Power Cable US Plug 1.8 M
- 1702002605 Power Cable EU Plug 1.8 M
- 1702031801 Power Cable UK Plug 1.8 M
- 1700000596 Power Cable China/Australia Plug 1.8 M
- EWM-W151H01E 802.11bgn RTL8188EE 1T1R, Half-size Mini-PCle (also need 9656EWMG00E)
- 9656EWMG00E Half-size miniPCle to Full-size miniPCle bracket set
- 1750000318 EMI Antenna 2DBI 2.4GHz SMA CONN for ARK-3384
- 1750003222 802.11b/g 5dBi Dipole Antenna
- 1750003418 Wireless Antenna AN2400-5901RS R/P SMA.M9dB
- TPC-1000H-WMKE TPC VESA Mounting Kit from 10" to 17" TPC
- TPC-1000H-SMKE TPC Stand kit from 10" to 17" TPC
- 1750000318 EMI Antenna 2DBI 2.4GHz SMA CONN for ARK-3384
- 1750003222 802.11b/g 5dBi Dipole Antenna
- 1750003418 Wireless Antenna AN2400-5901RS R/P SMA.M9dB

\* VESA support via a wall mounting kit

## Automation Software

- 968WEXP003X PanelExpress V2.0 300 tags S/W license
- 968WEXP015X PanelExpress V2.0 1500 tags S/W license
- 968WEXP050X PanelExpress V2.0 5000 tags S/W license
- 968WEXP2USB PanelExpress V2.0 S/W USB dongle

## Application Software

	<p>Version : V2.1 or above</p> <p>An innovative remote device management software, allowing efficient remote monitoring, quick recovery &amp; backup, and real-time remote configuration, to create a more intelligent and interconnected embedded computing solution.</p>
	<p>Version : V7.1 or above</p> <p>WebAccess, as the core of Advantech's IoT solution, is full web browser-based software package for HMI and SCADA software. All HMI and SCADA software features including: Animated Graphics Displays, Real-time Data, Control, Trends, Alarms and Logs, are available in a standard web browser. WebAccess is built around the latest internet technologies. With its open architecture, vertical domain applications can easily be integrated.</p>
	<p>Version : V2.0.3.8 or above</p> <p>Panel Express, a windows based HMI mini SCADA, realizes the cross platform flexibility offered by WebOP Designer to switch hardware for the consideration of cost and performance become an easy job. Panel Express software provides the best economic and express solution for data intensive high-end HMI applications.</p>
	<p>Version : V2.0.3.8 or above</p> <p>An easy to use integrated development tool featuring solution-oriented screen objects, high-end graphics, Windows fonts for multi-language applications. WebOP runtime, a part of WebOP Designer, guarantees reliability and performance because of the minimum system overhead, high communication data rates, and sub-second screen switching.</p>